

FLAT VERANDAHS

FREESTANDING

STRATCO OUTBACK® ASSEMBLY INSTRUCTIONS

Your complete guide to building a FREESTANDING Outback® VERANDAH, PATIO or CARPORT

BEFORE YOU START

Carefully read these instructions. If you do not have all the necessary tools or information, contact Stratco for advice. Before starting lay out all components and check them against the delivery docket. The parts description identifies each key part, and the component location diagram indicates their fastening position.

TOOLS REQUIRED

- Drill & Hex-Head Adaptor
- Rivet Gun
- Tape Measure
- Tin Snips
- Spirit Level
- Hack-Saw
- Post Hole Digger
- Silicone Gun
- Spanners or Ratchet
- Adjustable Construction Props
- Turn Up/Down Tool
- Concrete
- Ladder

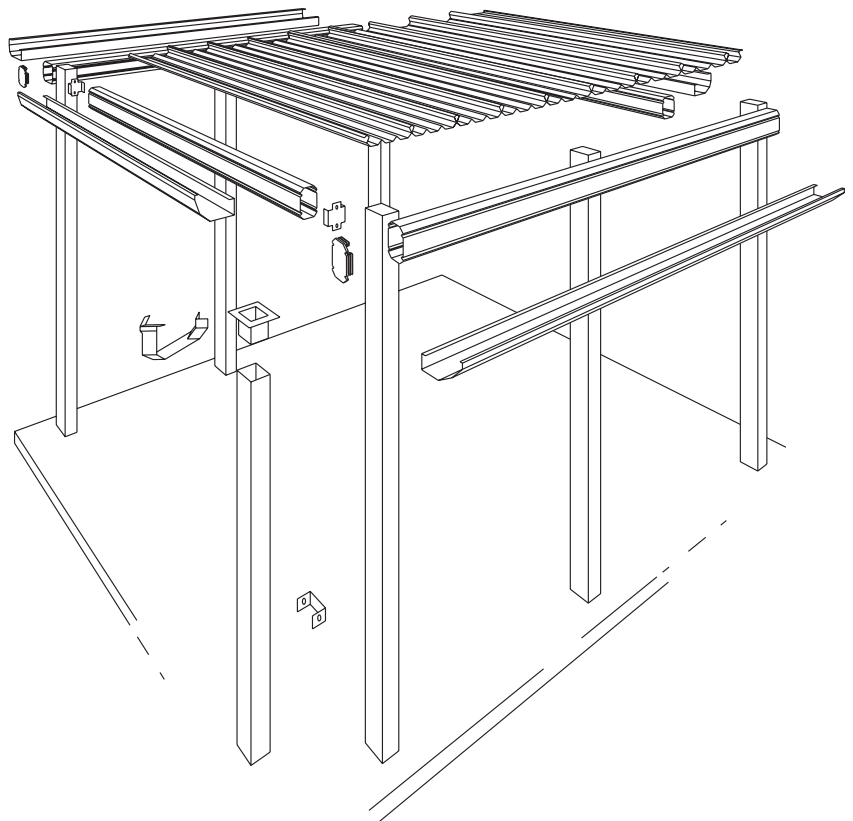

OUTBACK ROOFING
 Roof sheets cover 500mm and clip together to form a ceiling-like cover.



OUTBACK BEAMS
 The beams are the frame to support the roofing. Two sizes are available for different spanning requirements.

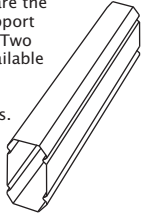

BEAM ENDCAP
 Endcaps enclose ends of beams.

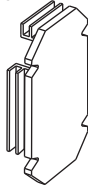

SPACERS
 Are used in conjunction with bolts to prevent beams from crushing.

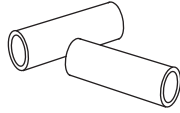

OUTBACK ROOFLITE™
 Polycarbonate sheets which cover 250mm and allow extra light penetration under the unit.

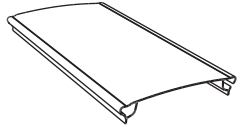

FREESTANDING FOOTING PLATE
 Allows the column to be secured to an existing slab.

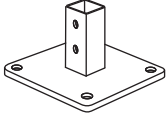

SHS Column Footing Plate

COLUMNS
 Support the beam framework.



BEAM TO BEAM BRACKET
 Forms a concealed connection between beams.

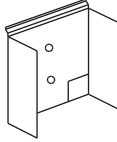

SCREWS AND RIVETS
 Fastener types vary depending upon the connection, ensure correct fixings are used.

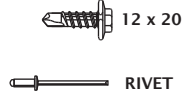

12 x 20
 RIVET

BOLTS
 Fastener types vary depending upon the connection, ensure correct fixings are used.

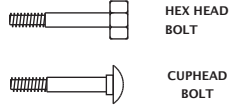

HEX HEAD BOLT
 CUP HEAD BOLT

BEAM IN-LINE CONNECTORS
 Join beams flush to form a continuous beam. Different connectors are available for various angles and loadings.

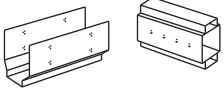

SHS POST CONNECTORS

Inline Connector

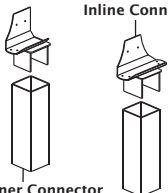

Corner Connector

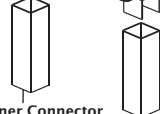

BEAM FILLERS
 Fills gap between intersecting beams.



DOWNPIPE
 Funnel water from the gutter to the ground via a 'pop'. Accessories of mitres, shoes and brackets are available as optional.



OUTBACK GUTTER
 The gutter adjoins the roofing to catch water run off. Accessories of stop ends, 'pops', straps and mitre brackets are available.

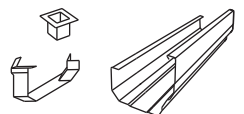

OPTIONAL EXTRAS

These items are available at request:

Concrete, Downpipe Mitres, Downpipe Shoes

COMPONENT LAYOUT

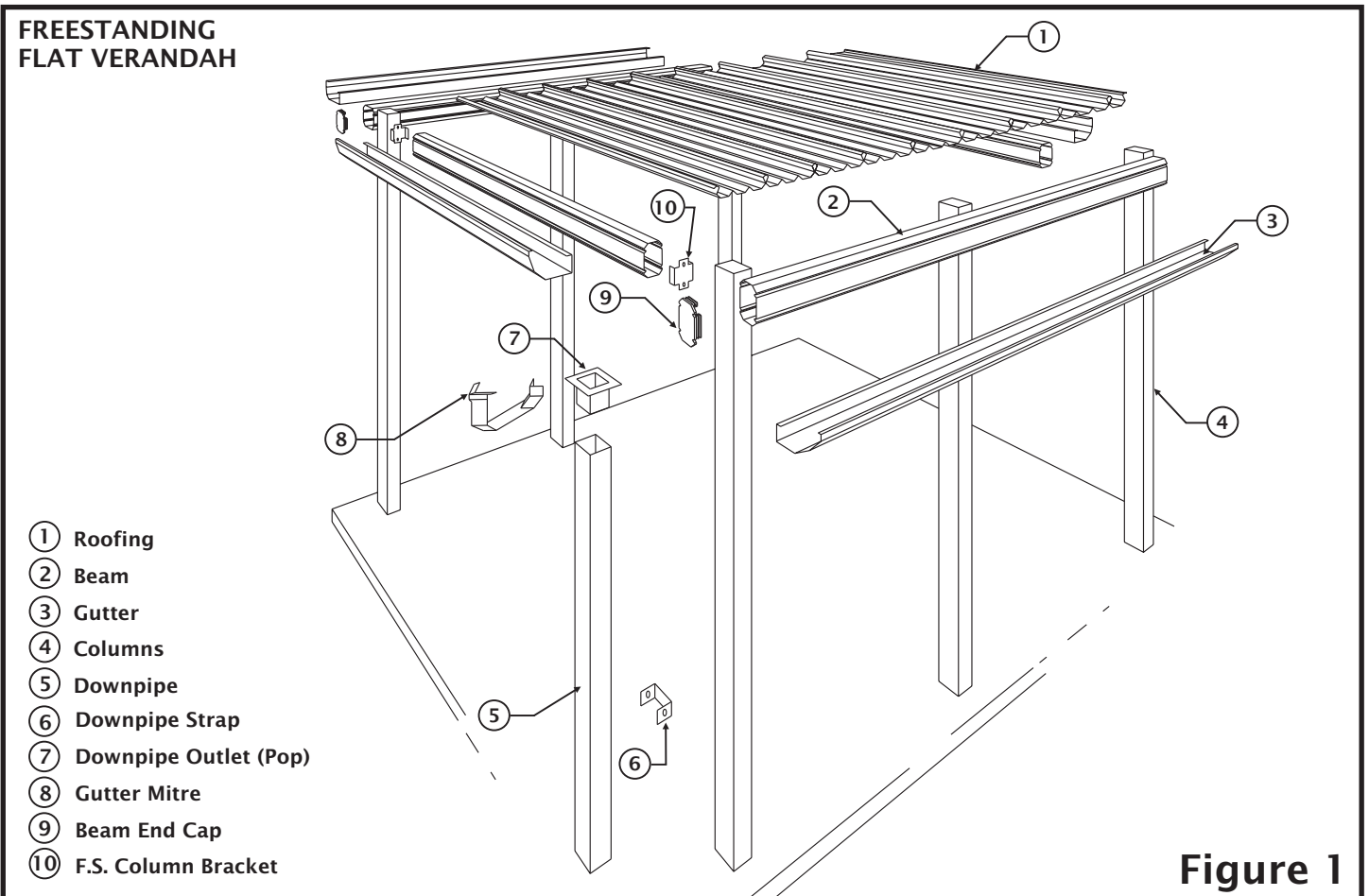

Figure 1

1.0 INTRODUCTION

It is important to check with your Local Government Authority prior to the installation of your new Stratco Outback Verandah.

Please read these assembly instructions thoroughly before commencing the construction and refer to them constantly during each stage of construction. Double check all dimensions, levels and bolting locations before cutting, screwing or bolting structural members. It is recommended that the persons erecting the structure have had some previous building experience.

2.0 MARKING OUT CARPORT POSITION

Mark out the overall area of your verandah, patio or carport and ensure it is free of obstructions. Ensure reasonable access for materials and working space and consider disposal of run-off water.

2.1 FOOTING HOLES

If your carport/verandah is to be secured in concrete footings check beam and column positions on the ground and mark out all hole locations. Dig footing holes to the required size as indicated on your specification sheet. Place a full or half brick in the bottom of the hole to support the column (Figure 2).

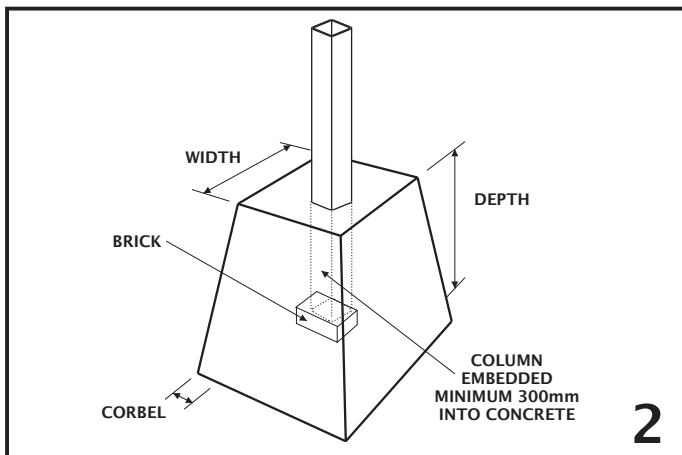

3.0 ASSEMBLING FRAMEWORK

3.1 COLUMNS

A number of alternatives (Figure 3) are available for fixing columns to Outback beams and the required length of your columns will depend on the system you are using. If SHS Inline Column Connectors are being utilised the top of the column is taken to the underside of beams less 5mm to account for the bracket thickness. For all other connection styles the top of the column is measured to the top of beams.

If your columns are being embedded into footings measure the column length from the top of the column to the top of the brick in the holes. Cut columns to length from the end which will be going into the ground taking into consideration unit fall.

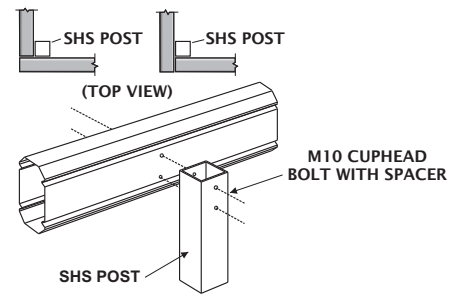

BOLTED COLUMN CONNECTION

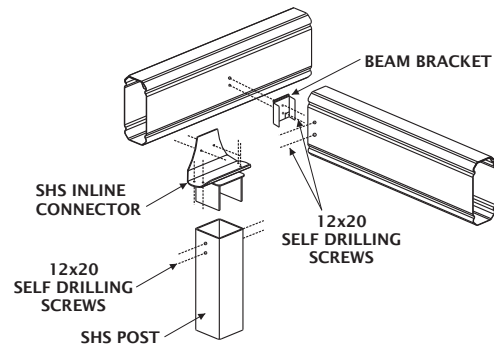

SHS INLINE CONNECTOR

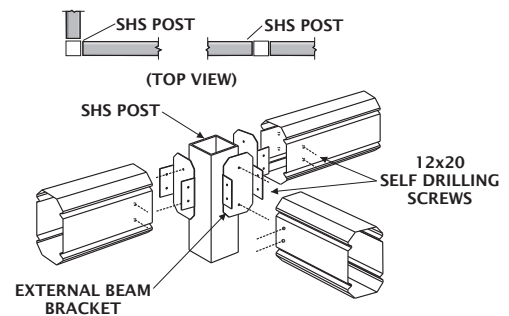

EXTERNAL BEAM BRACKETS

3

3.1.1 FREESTANDING VERANDAH FOOTING PLATE

A bolted footing bracket (Figure 4) is available if fixing columns to an existing concrete slab. Column lengths are taken from the top of the column to the concrete slab less the thickness of the footing base plate. Cut columns to length from the end which will be fixed to the footing plate taking into consideration unit fall.

Slide the footing bracket into the bottom of the column and fasten with two M10 bolts. Do not secure the base plates to the concrete slab at this stage.

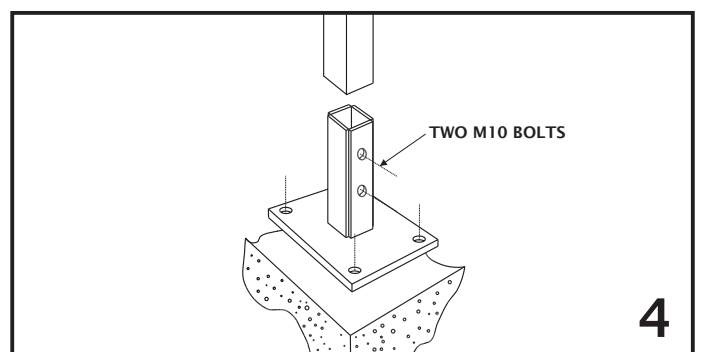

Note: The owner/erector is responsible for ensuring any existing slab is sufficient to support the Outback structure.

3.1.2 UNIT FALL

It is important to allow for deck slope and fall towards downpipe/s when sizing columns to avoid ponding of rainwater on the roof or in gutters. The minimum deck pitch is 1° for deck spans up to 4000mm and 1.5° for spans exceeding 4000mm. Carport/verandah units shall have a minimum fall of 1 in 500 (12mm for every 6m) towards downpipe/s.

3.2 PERIMETER BEAMS

Important: When installing all beams, ensure the double flange is on top.

Columns and beams brackets are fixed to the perimeter beams on the ground for ease of installation. Layout all beams in their intended locations and mark out the positions of all columns. Fixing requirements for column to beam connections are dependant on the style of connection being used.

3.2.1 SHS INLINE CONNECTORS

If you are using Inline Connectors they are secured to the beam with the high side of the bracket to the outside face of the beam. Secure the brackets to the beams using 12x20 self drilling screws through pre-drilled holes at the intended column locations. SHS Corner Connectors are used for any corner columns and come in both left and right hand corner brackets (Figure 5).

It is recommended two 5mm holes (vertically aligned) are pre-drilled to the column either side at approximately 30mm centres with the first hole beginning 15mm down from the top of the column. Slide columns over the Inline Connectors and screw in place with two 12x20 self

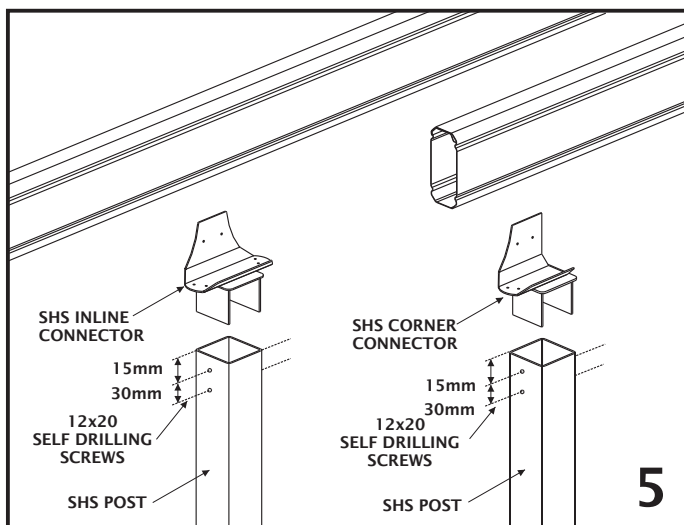

3.2.2 BOLTED COLUMN CONNECTION

If columns are to be bolted to the side of beams, columns will have been supplied with pre-drilled holes, you will have also received spacers to ensure beams are not crushed by bolted connections.

Drill 12mm holes all the way through Outback beams to match the hole locations in the columns. Enlarge the holes on the outside face of the beams (do not drill all the way through) to 16mm, this will allow the spacers to slide in from the outside face and stop at the other side (Figure 6).

Slide spacers over the M10 cuphead bolts and insert bolts from the outside face of the beams to secure columns in place.

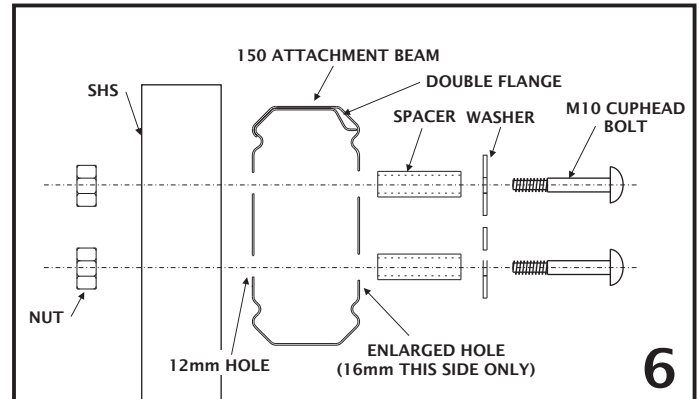

If perimeter and/or intermediate beams (where applicable) are to line up directly with the face of columns a freestanding column bracket must be secured with the protruding cuphead bolts (Figure 7).

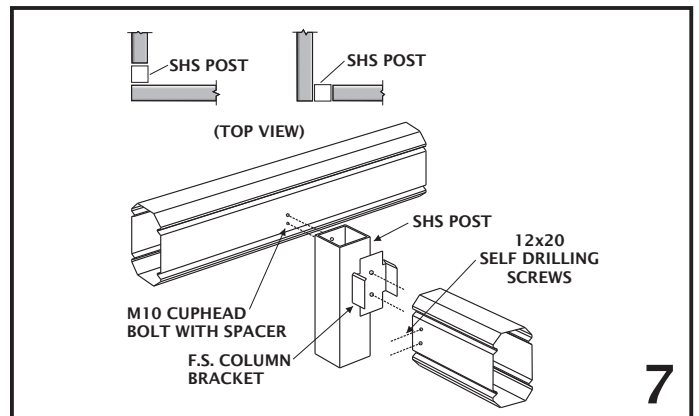

3.2.3 EXTERNAL BEAM BRACKETS

In the case External Beam Brackets are being utilised the beam ends are secured to the outside face of columns. Locate a bracket on any face of the column which will be accepting a beam so the top of the column will be inline with the top of the beams. Brackets are fixed to the column with two 12x20 hex head self drilling screws per bracket (Figure 8).

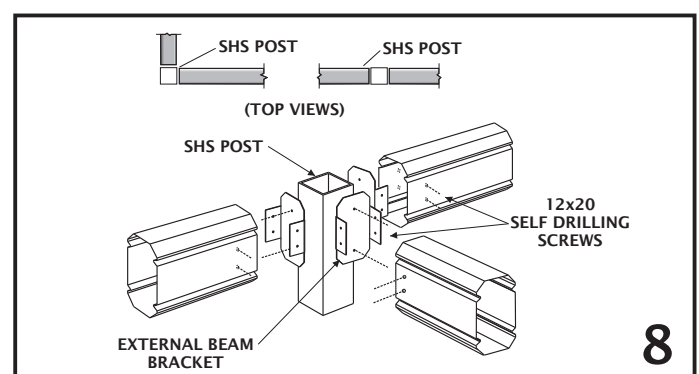

Secure the first side beam to be erected between two columns with two 12x20 self drilling screws either side to form a frame.

3.2.4 BEAM BRACKETS

Beam brackets will be required at the location of all beam intersects (except at location of freestanding column brackets or external beam brackets). Measure all beams, including intermediate beams (internal beams), marking the location of beam intersects.

Before securing beam brackets in place position beam fillers on the bottom flute of beams at the location of the beam brackets (fillers are not required when beams intersect directly above SHS Inline Column Connectors). Place beam brackets over beam fillers, aligning their curved flange with the top flute in the beam. Fasten through bracket holes into the beam with two 12x20 hex head screws so they clamp the fillers in place (Figure 9).

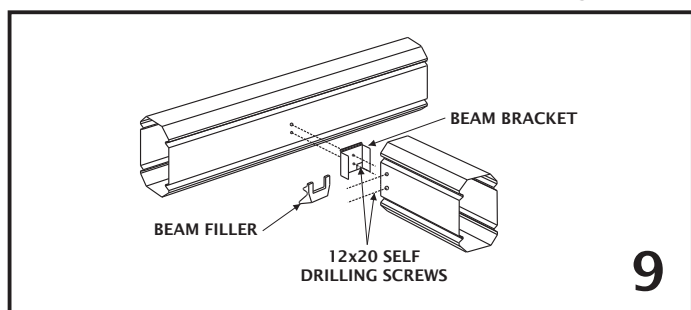

4.0 FRAMEWORK ERECTION

4.1 PERIMETER FRAMEWORK

Lift one of the perimeter frames into position, resting the columns on bricks inside footing holes or on their footing plates as applicable. Support the frame on adjustable construction props, ensure an accurate fall and check all columns are vertical, adjust if required.

Lift an adjacent perimeter beam into position and slide the beam onto its receiving bracket, support this beam on adjustable construction props. Adjust this beam for the appropriate fall and secure to the bracket with two 12x20 self drilling screws either side. Check all columns are vertical and adjust if required. Continue with the next perimeter frame and erect as per the above instructions. If internal framework exists (intermediate beams and purlins) it is recommended to be installed before fixing the final perimeter beam in place. If your unit does not include internal beams lift the final perimeter beam into position and secure in place as previously defined.

Do not concrete in place or anchor base plates at this stage. Leave all construction props and/or bracing in position.

4.2 INTERMEDIATE BEAMS & PURLINS

If intermediate beams and purlins are required, they are to be fitted before fitting the final perimeter beam. Work progressively from the first end securing beams to already installed brackets and supporting on adjustable construction props as required.

If your unit includes purlins install the first purlin prior to fixing the first intermediate beam in place, continue in this fashion progressively along the unit (Figure 10).

When all internal beams are fixed in place the final perimeter beam is located in position and secured to brackets as previously defined.

Do not concrete in place or anchor base plates at this stage. Leave all construction props and/or bracing in position.

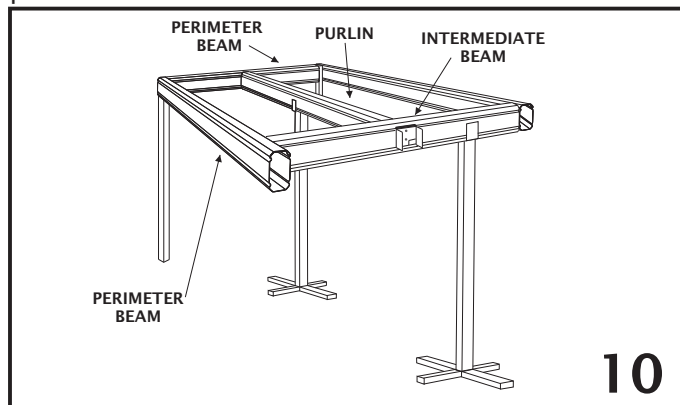

4.3 IN-LINE BEAM CONNECTION

In-line beam connectors are used to butt join beams when more than one length is required. This connector must be positioned so that the butting joint of the beams are in-line with the edge of the column.

Slide the in-line connector halfway inside the yet to be installed beam while it is on the ground. Fix the connector in place using four 12x20 hex head screws either side. Push the exposed half of the in-line connector into the other beam until both beams meet flush. Complete the connection by fastening the beam to the in-line connector as previously described (Figure 11).

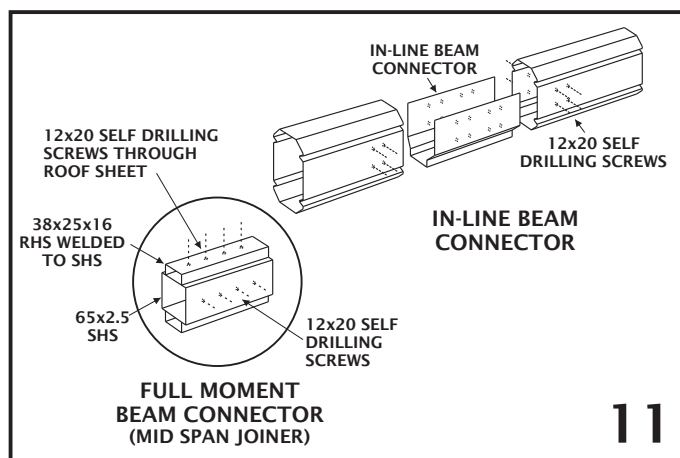

Note: If beams must be joined at a location other than over a post, a full moment beam connector is required (Figure 11).

4.4 CAPPING

To prevent moisture from entering the beams and for aesthetics, any beams with exposed ends require end caps be fitted. Apply a small amount of silicone to the back of the endcap, align the endcap and push into the exposed beam end.

5.0 FRAMEWORK CHECK

Check the basic framework for squareness by ensuring the diagonal measurements (A to C and B to D, Figure 12) are the same. Recheck that the falls are correct for the roof and gutter and all columns are vertical.

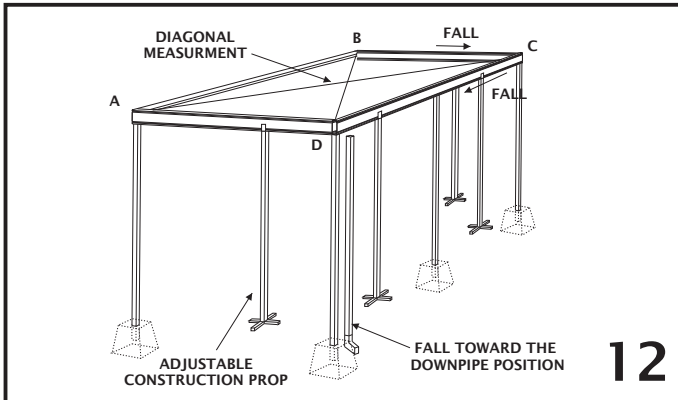

6.0 DECKING

While still at ground level, the ends of the decking overhanging into gutter need to be turned down approximately 30 degrees using a turn/down tool (Figure 13).

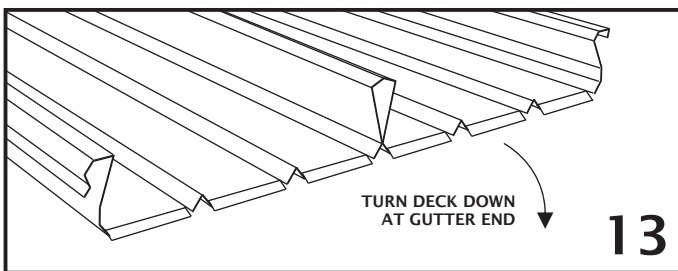

Decking should be positioned to allow a 50mm overhang into all of the gutters and should be laid with the overlapping rib away from the prevailing wind (Figure 14). Ensure that all of the sheets have locking ribs on the same side. Mark the perimeter beams every 1000mm to check that the decking is laid square.

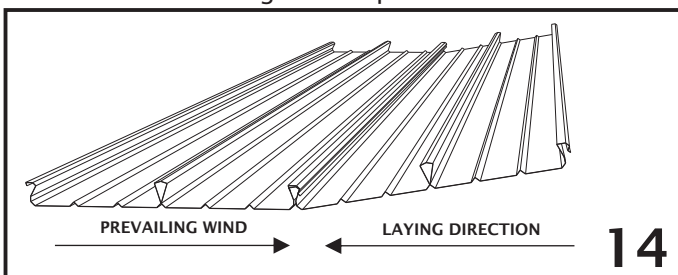

Begin installing the first sheet of decking. Lift the first sheet into place and check the sheet is square against adjacent perimeter beams. At each supporting beam fasten down the sheet with two 12x20mm hex head self-drilling screws per pan (Figure 15). Remove any swarf.

Lay the next sheet of decking over the previous sheet's side lap (Figure 14). Clip the sheet lap together working along the length using a timber block (to avoid damaging sheeting) and hammer. For larger spans it may be necessary to temporarily support the underside of roof sheeting while clipping laps together. Continue this process along the unit until all roof decking is installed.

For deck running parallel to beams secure with hex head

Note: In cyclonic conditions three 12x20mm hex head self-drilling screws are required per pan to supporting beams.

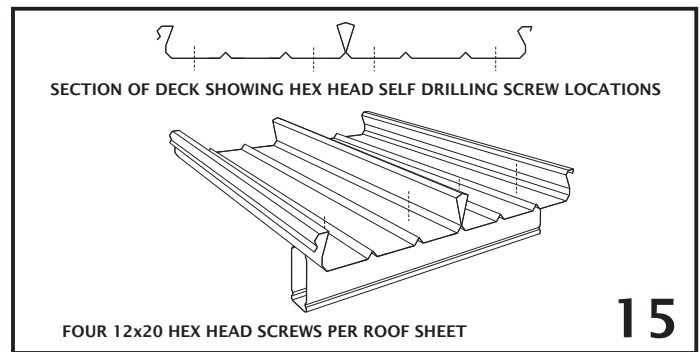

6.1 OUTBACK ROOFLITE

An Outback Rooflite® can be used for extra natural light. The polycarbonate Rooflite overlaps the Outback deck by snapping or sliding over already installed sheets spaced 250mm apart. Ensure the lower tab of the Rooflite touches the Outback deck at the points shown

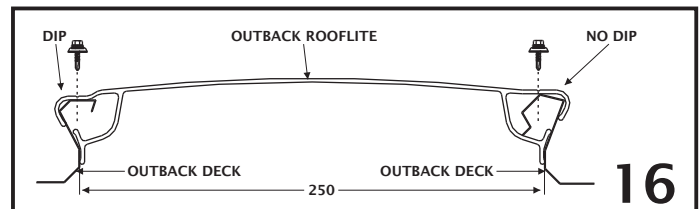

9mm holes must be predrilled through the Rooflite at all fastener locations prior to fixing to allow for thermal expansion. The Rooflite is fastened using 12x20mm hex head selfing drilling screws with domed washers at maximum 2000mm centres, fixing through the groove located along the top of the Rooflite connectors (Figure 17).

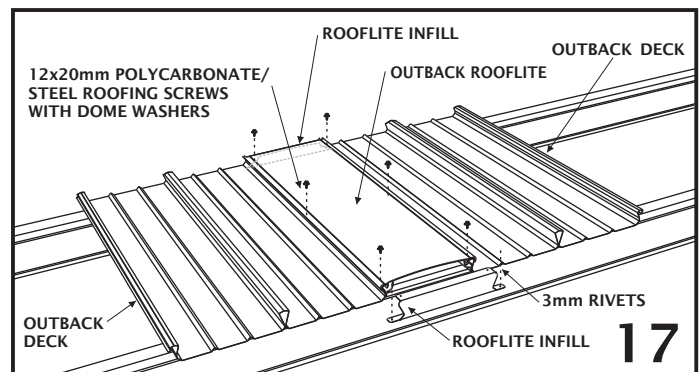

To finish the exposed ends of the Rooflite infill is required. Fasten the infill over the Rooflite with 12x20mm screws and domed washers on both sides through pre-drilled holes. Connect the infill to the underside of the decking with 3mm rivets and seal with silicone.

Note: The Rooflite profile is asymmetrical and must align with the correct deck connection (Figure 16).

7.1 GUTTER PREPERATION

To establish inside gutter length 'A' (Figure 18), measure the length of the perimeter beam and subtract 5mm for each mitre bracket.

To establish gutter length 'A' for units with deck overhang, subtract 50mm for each overhang from the total roof sheet length and subtract an additional 5mm for each mitre bracket.

Cut a 45 degree mitre on the ends of the gutters to fit the mitre brackets.

7.2 GUTTER MITRES

Installing gutters progressively, drill rivet holes for the gutter mitre brackets, remove swarf, and notch bracket if necessary to accommodate the pop. Fasten with rivets and silicone for a waterproof connection (Figure 18).

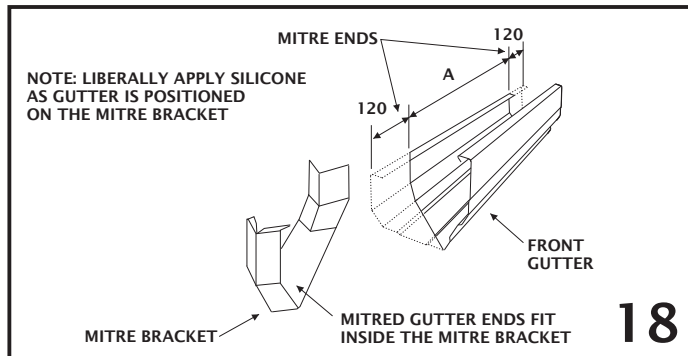

7.2 GUTTER OUTLET

Position downpipe in line with column/s. Cut a hole in the base of the gutter near the back chamfer. Insert the gutter outlet pop from the inside of the gutter and rivet in place using 3mm rivets (Figure 19), remove any swarf and waterproof with silicone.

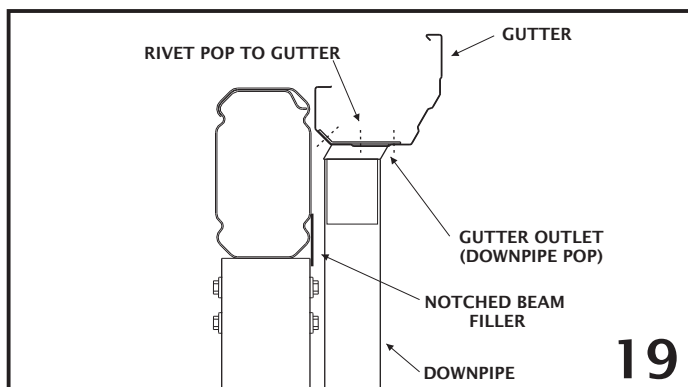

7.3 GUTTER INSTALLATION

When fixing gutters, check that the roof sheets overhang into the gutters by 50mm, the gutters are square in relation to the framework and that the front face of the gutter remains vertical and even.

Slide the flat end of the gutter straps inside the ends of the roof sheets every 1000mm (Figure 20).

Hang the first gutter on the straps and using a rolling action, lift the back of the gutter.

Fasten down through the roof sheets using rivets into the gutter's back lip at 1000mm maximum spacings and into the gutter straps. For overhang styles, use four rivets per sheet (two rivets per pan). Use silicone to waterproof rivets and around the strap where it meets the roof sheet.

Lift the next gutter into the installed mitre bracket.

Fasten down through the roof sheets into the gutter's back lip using rivets at 1000mm maximum spacings.

Position gutter straps at 1000mm centres. Rivet and seal the gutter to the mitre bracket and the straps to the roof sheets (Figure 20). Use the same method to attach the remaining gutters.

The downpipe is not attached at this stage as the columns are not yet fixed in their vertical position.

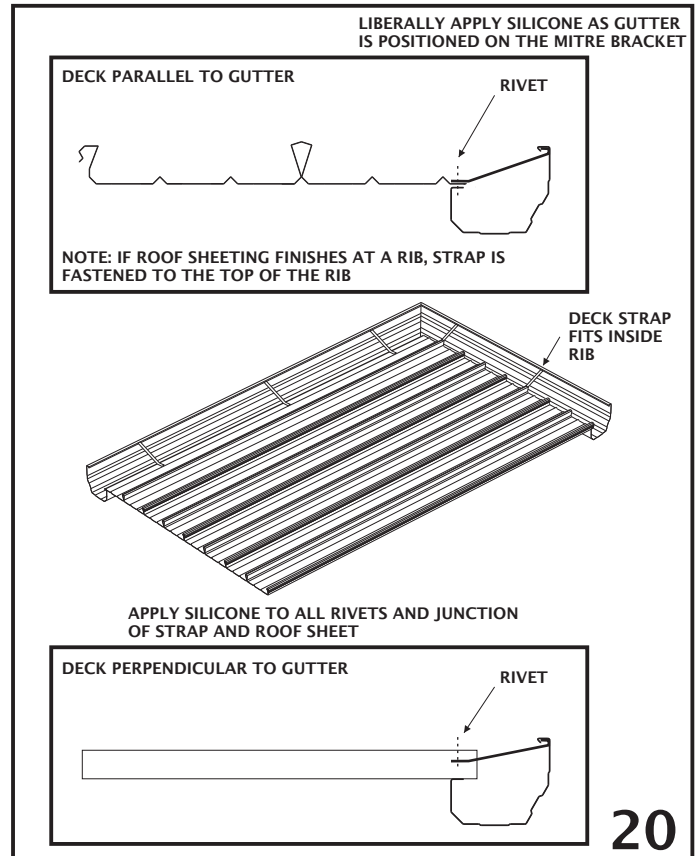

8.0 FINAL FIXING

8.1 COLUMNS

Thoroughly check the plumb of the columns with a spirit level. Fill the footing hole with approximately 150mm of concrete and use a shovel or pole to agitate the concrete to remove any air pockets. Repeat this process until the hole is full, continually checking the plumb of the columns. Once the concrete is set remove any temporary bracing or props.

Note: The concrete must be finished slightly raised towards the column, ensuring water runs away from the

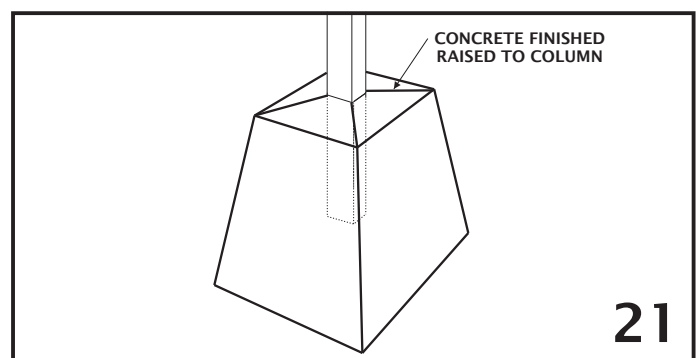

If fixing the columns to existing concrete with a Freestanding Verandah Footing Plate, each plate must be fixed to concrete with four M12 chemical anchors or equivalent (Figure 22).

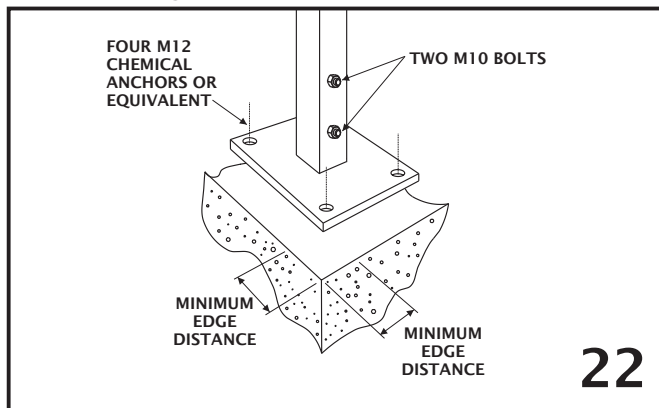

Note: The minimum distances from an anchor hole to the concrete edge is 75mm for M12 anchors.

8.2 DOWNPIPES

Before attaching the downpipe/s, rivet the downpipe bracket to the column and bend its flanges along the 'break-line' to accept the downpipe.

Slide the downpipe over the gutter outlet (pop) and rivet into position. Fix the downpipe to the downpipe bracket. Weatherproof all fasteners with silicone.

9.0 HELPFUL TIPS

Double check all measurements and drilling locations

Regularly check framework for squareness and vertical alignment to make sure it has not moved during construction.

Leave plastic coating on members until they are about to be fastened to the structure. This will help prevent scratching of the coloured finish.

Do not allow soil to remain in permanent contact with the columns, as corrosion will result in the base of the column. Refer to the "Selection, Use and Maintenance of Stratco Steel Products" brochure for complete details of the maintenance requirements.

Sweep the roof and clean gutters after the completion of work. Ensure any swarf and rivet stubs are removed as they can cause unsightly rust stains.

10.0 MAINTENANCE

Your Attached Stratco Outback Verandah, Patio or Carport will give you many years of service by simply following the important recommendations set out in the Stratco 'Selection, Use and Maintenance' brochure.

Wash and wipe down your Stratco Outback unit with a soft broom, mop or sponge as frequently as you would wash your car to maintain its duco. More frequent cleaning and rinsing will be required in severe environments.

In corrosive industrial or marine environments, the manufacturer recommends the use of colour steel with a stainless steel base. Contact Stratco for further details.