



---

**G A R A G E   D O O R S**

---

**CYCLOCK Series Roller Door  
Instruction Manual**

**Quality Australian Made Garage Doors**

# CYCLOCK Series Roller Door: INSTALLATION INSTRUCTIONS

1. Design loads for supporting structure that need consideration before installation of Stratco CYCLOCK door. During a cyclonic event the CYCLOCK door system transfers a significant load to the door's support structure. These loads need to be taken into account during the design of the doors support structure. The ultimate design loads as per AS/NZS 4505:2012 Appendix E and are outlined as follows:

3150mm Door	-	$F_x = 37.8\text{KN/M}$	$F_y = \pm 5.3\text{KN/M}$
4100mm Door	-	$F_x = 44.3\text{KN/M}$	$F_y = \pm 6.2\text{KN/M}$
5400mm Door	-	$F_x = 58.4\text{KN/M}$	$F_y = \pm 8.2\text{KN/M}$

Stratco only takes responsibility for the door and not its support structure or installation.

2. Check the width of the roller door against the opening to which the door is being fitted. For a standard installation the roller door curtain should be 70mm wider than the opening.
3. Referring to the table in the attached diagram, check the headroom, the side-room and the backroom to ensure there is enough room to fit the roller door.
4. Mark out the horizontal position for the brackets on the wall; the face of the angles should be facing away from the roller door. The brackets should be positioned well clear of the curtain edge, CYCLOCK clips and also clear of the Guide Tracks and any Track Brackets.
5. Mark the vertical position of the brackets above the opening. Refer to the attached diagram. Level the two brackets at the horizontal arms using a water level or other suitable device.
6. Attached the brackets to the wall by either screwing or welding (if steel frame work). Supplied with the roller door kits are steel and wood fixing screws and washers which must be used in the following ways:
  - For steel fixing, four or more self-drilling/tapping screws must be used to secure each bracket to the wall.
  - For timber fixing, three or more 2" x 5/16" Hex. Head Coach Screws must be used per bracket.
  - For brick or concrete fixing, depending on the type and condition of the brick or concrete, use three or more 10mm dia. bolts from the outer surface of the wall, 125mm x 10mm 'Dynabolts' or 2" x 5/16" Hex. Head Coach Screws and plastic plugs per bracket. (The installer must assess what is appropriate in each situation).

Flat washers must be used under all screw heads.

7. If an Electric Operator is to be used, mount the unit onto the axle at the correct end now and install with reference to the manufacturer's instructions. Lift the roller door onto the brackets with the door orientated such that the colour side will face outward from the opening. Using the two 'U' bolts and saddles, loosely secure the roller door axle upon the brackets.

**Extreme Safety Risk:** *Safe practices must be observed when lifting roller doors as they can weigh up to 200kg. The installer must ensure the roller door is secure and safe at all times.*

*The Wall Brackets are designed to support the door only and using the Wall Brackets to mount the door lifting gear is NOT recommended by Stratco. Any injury or damage arising from this practice will be the installer's responsibility and is NOT covered by the door warranty.*

8. Centre the roller door within the opening with the same amount of curtain overlap each side. Rocking the roller door on its axle will assist the door to move into position. Position the Electric Operator as required at the same time.
9. Move the door to the rear of the bracket slots and turn the axle to allow the door to be relaxed on the axle with the Bottom Rail at the bottom of the curtain (6 o'clock position).
10. **Fully tighten the two 'U' bolts** to clamp the axle to the brackets.
11. Now turn the curtain roll **1 turn towards the wall**, as viewed from above, and hold in this position. The door now has **1 turn** of spring pre-tension.

12. **Without letting go of the curtain**, remove any associated packaging. Holding the Bottom Rail, the curtain may now be fully opened and closed to ensure the roller door is rolling up in correct alignment on the roll prior to fitting the Guide Tracks. Take care to avoid the nylon braiding touching the wall. A softwood check may now be carefully positioned between the Bottom Rail and the curtain roll to prevent the door unrolling. Refer to attached diagram.
13. Cut the bottom off the tracks to suit the particular opening height such that the underside of the top stop is level with the top of the opening. Refer to the diagram. Note that this is the normal set-up and part of the Bottom Rail and the Weather Seal will protrude 20mm into the opening when the door is open.
14. Flare out both the side and rear faces at the track top where the track is notched back and pre-slit to give the angles as shown in the attached diagram. The rear face is bent back about 8mm to avoid the nylon webbing from catching on the sharp edge. Refer also to the note to bend away the track front (wall) face so as to avoid the webbing catching if the door is installed high. After fitting the tracks, if necessary adjust the angles to enable smooth entry of the curtain into the top of the track.
15. Attach track against the wall so there is a 3 to 6mm gap between the inside of the track and the CYCLOCK clip. Using a builders level, ensure the tracks are vertical then fix to the (frame wall certified by others to resist specified loads) using bolts. Refer to diagram attached.

The stiffener bracket when the door is in the down position must line up with the CYCLOCK clip.

**NOTE:** before fully fastening the tracks, operate the door fully to ensure it is not binding in the tracks at any point.

16. **With the door in the open position** and working at only one end of the door at a time, loosen the 'U' bolt and, by using the slots in the wall brackets, move the door in towards the wall until just about touching the track front face but avoiding any binding and re-tighten the 'U' bolt.

**Ensure both 'U' bolts are fully re-tightened.**

17. After operating the door a few times, check the door balance.

When correctly balanced, the roller door should have a tendency to lift slightly at the top and bottom positions and be neutral or slightly heavy at mid height. If fitting an Electric Operator weight bar to the bottom rail., apply a little more tension but leave the door a little heavy.

If necessary, adjust the springs as follows:

**With the door in the open position**, loosen the 'U' bolt at one end of the door first. Then while holding the axle from turning at the other end with a pipe wrench, loosen the other 'U' bolt. The handle of the wrench will want to lift towards the ceiling. Turn the axle with the wrench in the direction required to adjust the door balance. Raise the wrench to reduce spring tension and make the door 'heavier', lower to 'lighten' (refer to the diagram).

Now fully re-tighten both "U" bolts before operating the door down below half height.

18. To cut lock holes into track with the door in the fully closed position, mark the nylon retainer height positions and cut a hole in the side face of each track for the locking bars to slide through (this is not required if motorised).
19. Remove the adhesive film from the outside face of the curtain.
20. To maintain the roller door's finish and smooth operation, adhere to the care instruction label on the rear face of the bottom rail.

# CYCLOCK SERIES GUIDE TRACK

(Suggested Positioning)

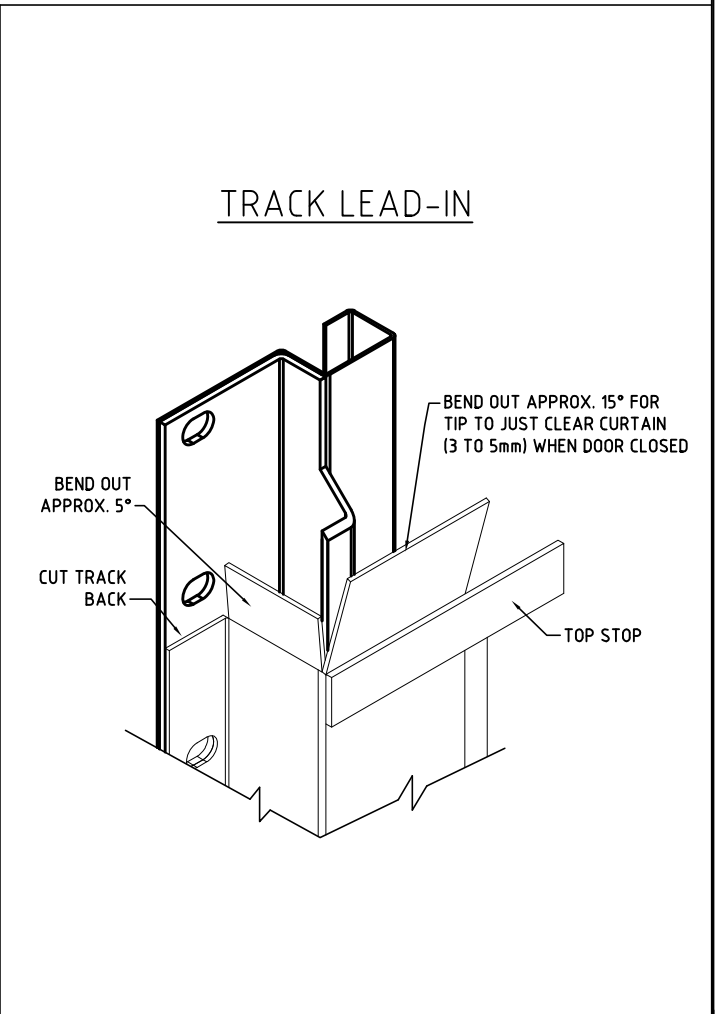
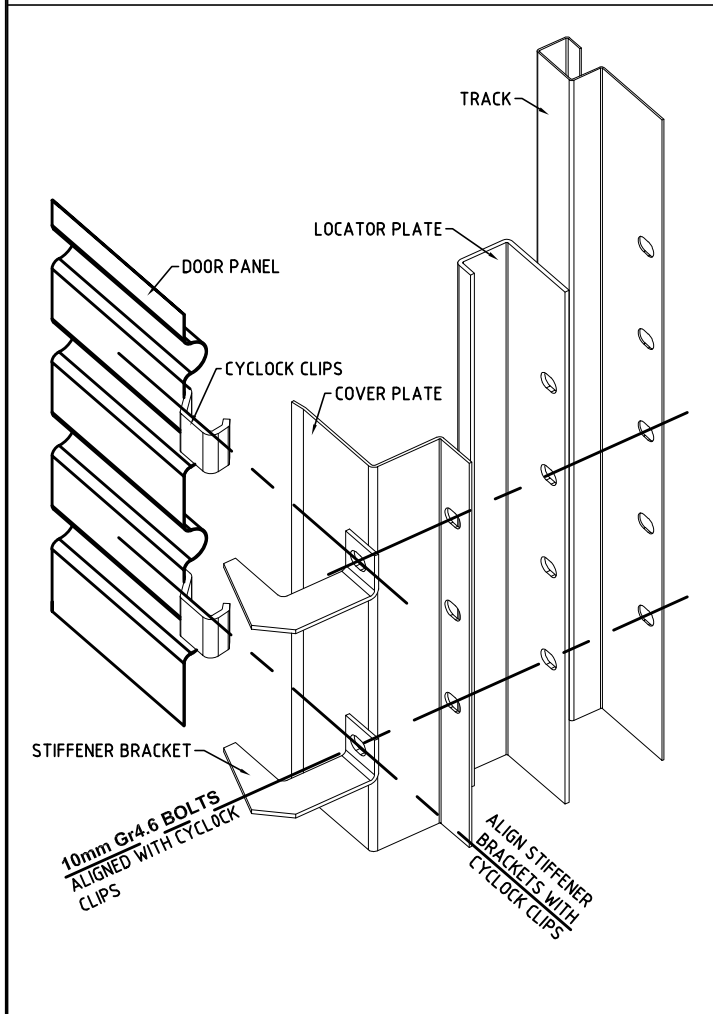
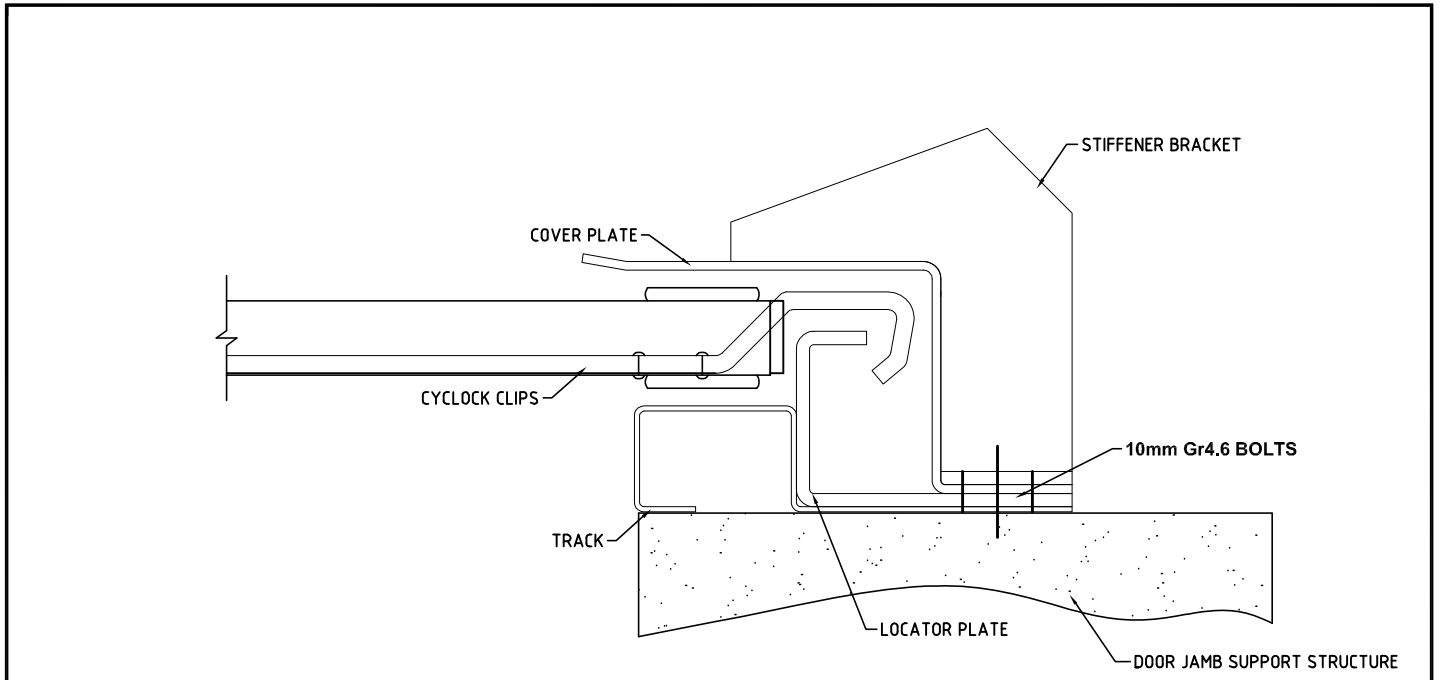



# GARAGE DOORS

## Cyclock Series Roller Door

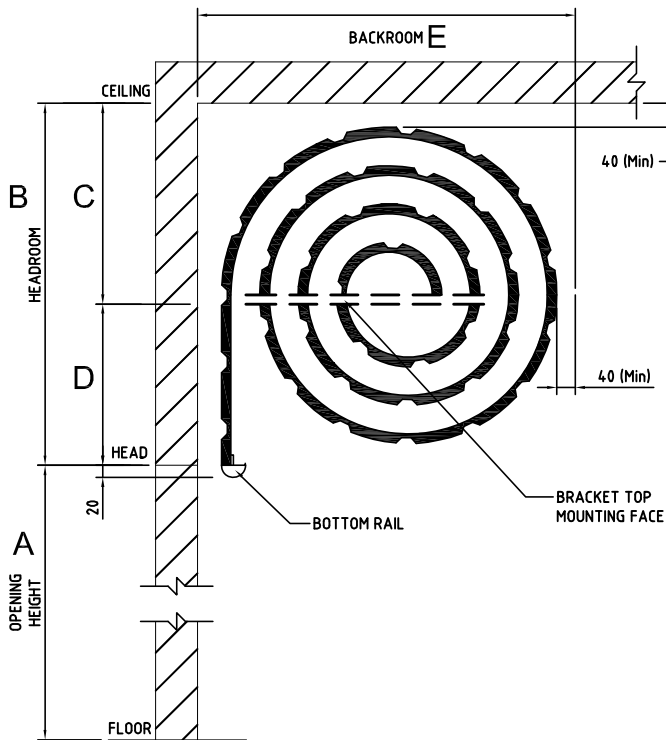
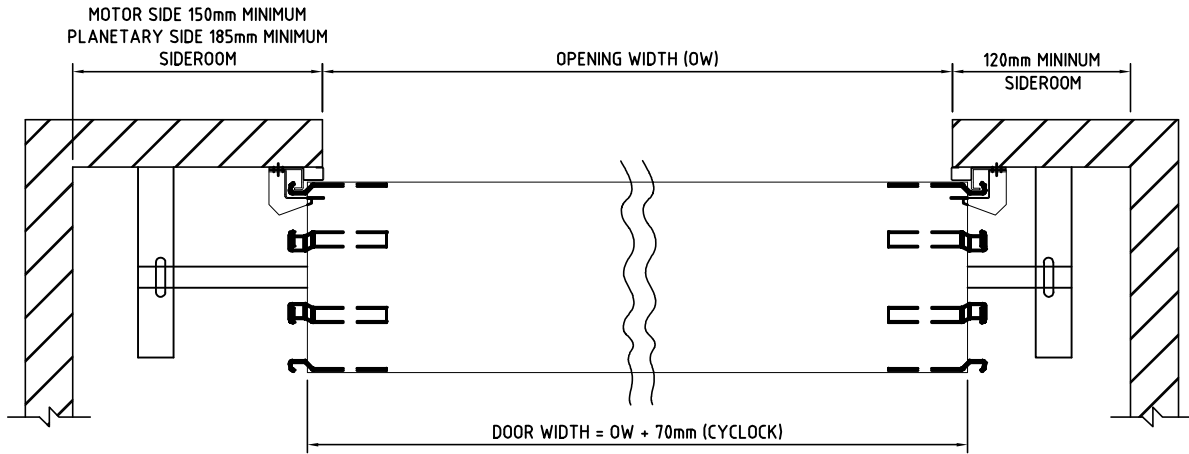

**INITIAL SPRING TENSION:**  
ROTATE DOOR ONE TURN WITH  
THE DOOR STILL STRAPPED AND  
THE AXLE CLAMPED TIGHT.

**FINAL SPRING TENSION:**  
AFTER INSTALLATION, ADJUST  
DOOR BALANCE BY HOLDING  
AXLE WITH WRENCH, UNCLAMP  
AXLE, ROTATE AXLE AS  
REQUIRED AND RECLAMP.

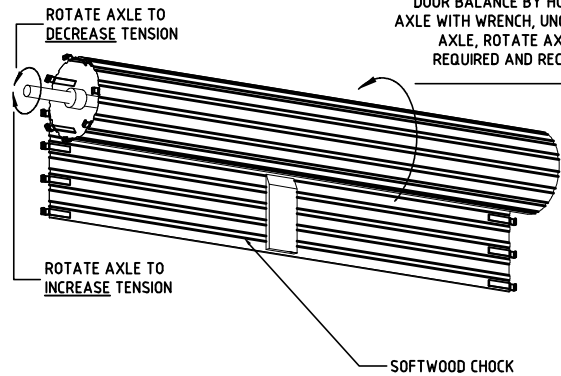

	Opening Height	Headroom			Backroom
	A	B	C	D	E
<b>'A' Series</b>	1200	430	265	165	460
	2200	440	270	170	485
	2400	455	275	180	505
	2800	485	295	190	515
	3000	495	300	195	525
<b>'B' Series</b>	3900	520	310	210	565
	4600	535	325	210	580
	5100	550	340	210	595

## Form 15—Compliance Certificate for building Design or Specification

NOTE	<p>This is to be used for the purposes of section 10 of the <i>Building Act 1975</i> and/or section 46 of the <i>Building Regulation 2006</i>.</p> <p>RESTRICTION: A building certifier (class B) can only give a compliance certificate about whether building work complies with the BCA or a provision of the QDC. A building certifier (Class B) can not give a certificate regarding QDC boundary clearance and site cover provisions.</p>									
<p><b>1. Property description</b> This section need only be completed if details of street address and property description are applicable. EG. In the case of (standard/generic) pool design/shell manufacture and/or patio and carport systems this section may not be applicable.</p> <p>The description must identify all land the subject of the application.</p> <p>The lot &amp; plan details (eg. SP / RP) are shown on title documents or a rates notice.</p> <p>If the plan is not registered by title, provide previous lot and plan details.</p>	<p>Street address <i>(include no., street, suburb / locality &amp; postcode)</i></p> <div style="border: 1px solid black; padding: 2px;">Varies – C2 maximum wind rating</div> <hr/> <p>Lot &amp; plan details <i>(attach list if necessary)</i></p> <div style="border: 1px solid black; height: 20px;"></div> <p>In which local government area is the land situated?</p> <div style="border: 1px solid black; height: 20px;"></div>									
<p><b>2. Description of component/s certified</b> Clearly describe the extent of work covered by this certificate, e.g. all structural aspects of the steel roof beams.</p>	<p>Structural Design of the <b>Cyclock Roller Doors</b>, Manufactured by Napoleon Garage Doors to meet a wind <b>Rating of C2</b>.</p> <p>This certificate covers doors of width up to and including 5400mm. James Cook University has tested three widths of door, 3150mm, 4100mm &amp; 5400mm wide. The spacing of the locking clips varies between each door width tested. When selecting the configuration of door see below.</p> <p>For Doors <math>\leq 3150</math>mm adopt the 3150mm door configuration. For Doors <math>&gt;3150</math> &amp; <math>\leq 4100</math>mm adopt the 4100mm door configuration. For Doors <math>&gt;4100</math> &amp; <math>\leq 5400</math>mm adopt the 5400mm door configuration.</p> <p>This certificate covers (provided they have been constructed as per the design drawings and tested configurations) the door tracks, cyclone locks and door panel as supplied by Napoleon Garage Doors</p> <p><b>Excluding:</b> - The doors have not been tested to withstand Impact. - This certificate excludes the design of the doors supporting structure to which the tracks are connected to. These are to be designed and certified by others to withstand the following loads.</p> <p><b>Design loads on supporting structure.</b></p> <p>During a cyclonic event the Cyclock Door system transfers a significant load to the doors support structure due to catenary action. These loads need to be taken into account during the design of the doors support structure. Example Ultimate design loads as per AS/NZS 4505:2012 Appendix E are outlined as follows:</p> <table style="width: 100%; border-collapse: collapse;"> <tr> <td style="width: 30%;">3150mm Door</td> <td style="width: 30%;">Fx= 37.8 kN/m</td> <td style="width: 30%;">Fy= <math>\pm 5.3</math> kN/m</td> </tr> <tr> <td>4100mm Door</td> <td>Fx= 44.3 kN/m</td> <td>Fy= <math>\pm 6.2</math> kN/m</td> </tr> <tr> <td>5400mm Door</td> <td>Fx= 58.4 kN/m</td> <td>Fy= <math>\pm 8.2</math> kN/m</td> </tr> </table> <p>For doors of varying width than those above – consult AS4505 for appropriate loading.</p> <hr/> <p>FORM Structural Engineers Job Number 1300-007</p>	3150mm Door	Fx= 37.8 kN/m	Fy= $\pm 5.3$ kN/m	4100mm Door	Fx= 44.3 kN/m	Fy= $\pm 6.2$ kN/m	5400mm Door	Fx= 58.4 kN/m	Fy= $\pm 8.2$ kN/m
3150mm Door	Fx= 37.8 kN/m	Fy= $\pm 5.3$ kN/m								
4100mm Door	Fx= 44.3 kN/m	Fy= $\pm 6.2$ kN/m								
5400mm Door	Fx= 58.4 kN/m	Fy= $\pm 8.2$ kN/m								

### LOCAL GOVERNMENT USE ONLY

Date received	Reference Number/s
---------------	--------------------

The *Building Act 1975* is administered by the  
Department of Housing and Public Works



**Queensland  
Government**

<p><b>3. Basis of certification</b> Detail the basis for giving the certificate and the extent to which tests, specifications, rules, standards, codes of practice and other publications, were relied upon.</p>	<p>AS/NZS1170.2:2011 Structural Design Actions, Wind Actions, AS4100 Steel Structures, AS/NZS 4505:2012 Garage Doors &amp; Other Large Access Doors</p> <p>James Cook University Cyclone Testing Station Report Numbers. TS941 11<sup>th</sup> April 2014 &amp; TS964 1<sup>st</sup> August 2014. Tested to withstand C2 wind loading</p> <p>Doors to be installed as per the design documents.</p> <p>NOTE: This Certificate is valid until the 30<sup>th</sup> June 2018 at which point the test results need to be reappraised by James Cook University (JCU) to ensure that they still meet current codes of practise at that time. A new certificate will need to be generated for items manufactured after this date. Please refer to JCU Test Summary Sheet – TS941 – Note 2.</p> <p>Site classification is to be undertaken by others. The doors have been rated to withstand a C2 loading. Building designers and certifiers must be vigilant to ensure these doors are not used in locations that would exceed this specification. Specific Site classification is outside the scope of this certificate.</p>
<p><b>4. Reference documentation</b> Clearly identify any relevant documentation, e.g. numbered structural engineering plans.</p>	<p>Napoleon Garage Doors Drawings – 1300-007-SK01 Sheets 1 to 6.</p> <p>Full scale physical testing of the 3150mm Door &amp; 4100mm Door as outlined in James Cook University Cyclone Testing Station Report No. TS941 11<sup>th</sup> April 2014.</p> <p>Full scale physical testing of the 5400mm Door as outlined in James Cook University Cyclone Testing Station Report No. TS964 1<sup>st</sup> August 2014.</p>
<p><b>5. Building certifier reference number</b></p>	<p>Building certifier reference number</p> <p>Not Known</p>
<p><b>6. Competent person details</b> A competent person for building work, means a person who is assessed by the building certifier for the work as competent to practise in an aspect of the building and specification design, of the building work because of the individual's skill, experience and qualifications in the aspect. The competent person must also be registered or licensed under a law applying in the State to practice the aspect.</p> <p>If no relevant law requires the individual to be licensed or registered to be able to give the help, the certifier must assess the individual as having appropriate experience, qualifications or skills to be able to give the help.</p> <p>If the chief executive issues any guidelines for assessing a competent person, the building certifier must use the guidelines when assessing the person.</p>	<p>Name (<i>in full</i>)</p> <p>Steven Rode-Bramanis</p> <p>Company name (<i>if applicable</i>)</p> <p>FORM Structural Engineers Pty Ltd</p> <p>Contact person</p> <p>Steven Rode-Bramanis</p> <p>Phone no. <i>business hours</i></p> <p>3114 3143</p> <p>Mobile no.</p> <p>0420 821 958</p> <p>Fax no.</p> <p>Email address</p> <p>steven@formeng.com.au</p> <p>Postal address</p> <p>PO Box 7202, Redland Bay QLD</p> <p>Postcode 4165</p> <p>Licence or registration number (<i>if applicable</i>)</p> <p>RPEQ 12193</p>
<p><b>7. Signature of competent person</b> This certificate must be signed by the individual assessed by the building certifier as competent.</p>	<p>Signature</p> <p>Date</p> <p>5<sup>th</sup> August 2014</p>